

## LIGHTING MANUAL



# PROMOTING QUALITY OUTDOOR LIGHTING IN YOUR COMMUNITY

A Technical Assistance Series Prepared By:

Maine State Planning Office

Hancock County Planning Commission

With input from professional and citizen planners, including:

Acadia National Park

The Island Astronomy Institute

Kennebec Valley Council of Governments

Washington County Council of Governments

Financial assistance was provided by the Maine State Planning Office through the Office of Ocean and Coastal Resource Management, National Oceanic and Atmospheric Administration, US.





# PROMOTING QUALITY OUTDOOR LIGHTING

On a clear, dark night about 2,500 stars should be visible to the naked eye. On the same night in a moderately illuminated suburban area, only 300 stars can be seen.

Outdoor lighting is important for safety, visibility and publicity of a business. Not all lighting is equal, however. Much outdoor lighting is wasted since it is not aimed at its target and escapes to the sky.

The challenge is to determine what is adequate lighting - i.e., lighting that is the least intensity necessary to accomplish the light's purpose. Adequate lighting recognizes that different land uses have different lighting design needs.

Successful designs do not threaten nighttime security, safety and utility, but reduce energy waste, emit less light pollution, and keep skies dark.

This bulletin explains the differences between good lighting practices and those that have a negative impact on neighboring properties, safety, the natural environment and even health. It introduces the concept of light pollution. It also presents examples of good lighting practices and has standards that could be incorporated into a land use ordinance.

Our excessive use of lighting is remarkably clear from outer-space. This bulletin contains important information to help your community reduce light pollution.

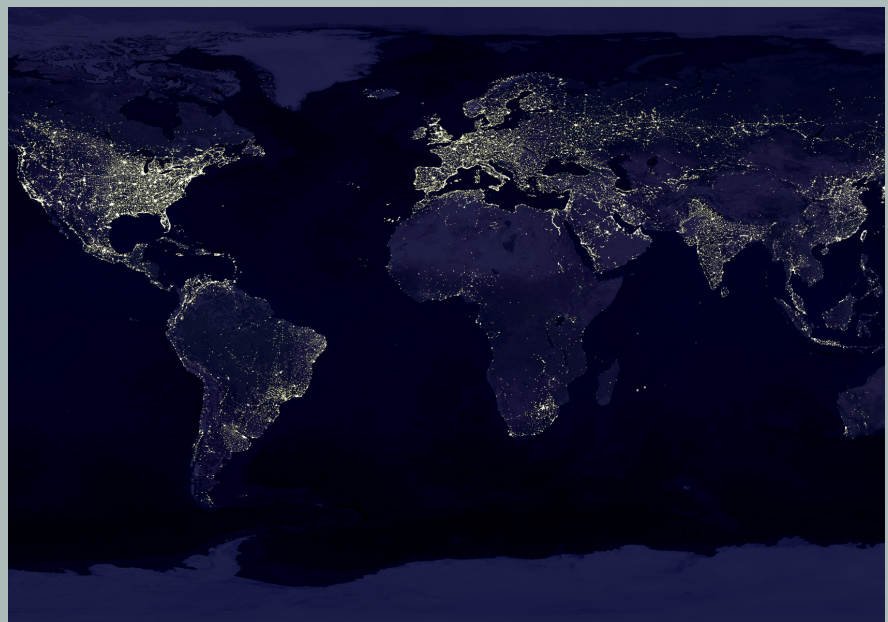



No Sky Glow - the night sky with good lighting.<sup>1</sup>



Sky Glow - the night sky with excessive and bad lighting.<sup>2</sup>



Many lighthouses use lower wattage lights than those used in domestic security lights.

### What is Light Pollution?

Light pollution is artificial light that is allowed to illuminate, or pollute, areas not intended to be lit. There are five types of light pollution defined below. One light may generate more than one type of light pollution.

**LIGHT TRESPASS:** Lighting on one property that intrudes unnecessarily on an adjoining property or public way. For example, light trespass occurs when a strong light enters the window of one's home from outside, causing problems such as sleep deprivation or the blocking of an evening view.

**OVER ILLUMINATION:** The excessive use of light. According to the International Dark Sky Association, over-illumination accounts for approximately two million barrels of oil per day in energy wasted in the United States, resulting in 4% of our daily oil consumption being used for wasted light.

**GLARE:** An extreme contrast between bright and dark areas in the field of view. Glare is particularly problematic for road safety, as badly shielded lights along roads may partially blind drivers or pedestrians unexpectedly, and can obscure night vision for up to an hour after exposure.

**CLUTTER:** An excessive grouping of lights. These groupings may generate confusion and distract from obstacles, including those that they are intended to illuminate. Clutter is particularly noticeable on roads where the street lights are badly designed, or where brightly lit advertising lines the roadways.

**SKY GLOW:** The "glow" effect that is visible above populated areas. It is the result of all of the badly directed light in an area being refracted in the surrounding atmosphere.

### Why is Light Pollution a Problem in Maine?

While we generally think of ourselves as a rural state, we do have substantial commercial development, even in many small towns. Poorly planned outdoor lighting causes several problems:

**ENERGY WASTE** If half the light from a bulb is directed upwards, effectively serving no purpose, then it could be replaced with a bulb using half the energy if all of its light is directed downward.

**NUISANCE FOR ADJACENT PROPERTIES** A commercial operation may have its lighting spill over onto a private home next door.

**LIGHT COMPETITION** A small-scale business may have modest lighting arrangements. Then, a gasoline station opens next door and installs very bright lights. The first business loses its visibility since it is obscured by the brighter lights next door. In response, the first business installs brighter lights. This can happen over an entire commercial area.

**MISCONCEPTIONS ABOUT SECURITY LIGHTING** According to the International Dark-Sky Association, there are no credible scientific studies that convincingly show a direct relationship between increased lighting and reduced crime. Furthermore, the association claims that badly installed artificial lights can create a deeper contrast of shadows in which criminals might hide. Also, more is not necessarily better - a British study maintains that many lighthouses use lower wattage lights than those used in domestic security lights.

**ADVERSE HUMAN HEALTH EFFECTS** Medical research has shown that excessive light on the human body may increase incidents of headaches, fatigue, stress and anxiety.

Why is Light Pollution a Problem in Maine? continued

**DISRUPTION OF ECOLOGICAL PROCESSES** Light pollution around lakes may inhibit plankton from eating surface algae. This has serious implications as high levels of algae, or algal blooms can kill off the lakes' plants and cause significantly lower water quality. Nocturnal amphibians may also be affected by light pollution because they emerge from concealment later than usual, giving them less time to mate and reproduce.

**DIMINISHED ENJOYMENT OF THE NIGHT SKY** Unnecessary or inappropriate outdoor lighting can threaten the rural character treasured by many residents and visitors of Maine. According to the Smart Communities Network, on a clear, dark night about 2,500 stars should be visible to the naked eye. On the same night in a moderately illuminated suburban area, only 300 stars can be seen.

energy inefficient. High pressure sodium (HPS) lamps are efficient and long lasting, but emit an orange-yellow light that distorts color and the ability to distinguish features at a distance. Metal halide lights emit a cool white light, which allows for a more accurate object identification.



**4. AIM LIGHTS AT THEIR INTENDED TARGET.** Fixtures can be installed with shields that prevent light from escaping into the sky. Lights can also be positioned so that they do not shine onto adjoining properties. For example, lights should be positioned above an externally illuminated sign and aimed downwards. Full-cut, shielded fixtures, that emit no light above the horizontal, give more light on the ground. See graphics below: <sup>3</sup>

How Can We Promote Good Lighting?

**1. AVOID OVER-LIGHTING.** Lighting is measured by foot candles. The foot candles of various light types are shown below. Foot candles can be measured by a light meter. As of mid-2007, a digital meter could be purchased for about \$175.

ILLUMINANCE VALUES	
Full Moonlight	0.01 to 0.1 foot candle
Pre-dawn	0.1 to 1 foot candle
Windowed room on a cloudy day	6-8 foot candles
Beach in bright sunlight	30,000 foot candles

Source: Outdoor Lighting Manual for Vermont Municipalities, Chittenden County Regional Planning Commission, 1996

**2. ENCOURAGE USE OF MOTION DETECTORS FOR SECURITY LIGHTING.** At least some security lighting can use motion detectors that turn on the light only when there is motion on the property.

**3. BE AWARE OF THE IMPACT OF DIFFERENT LIGHTING TYPES.** For example, blue lights have far greater impact on the night sky than yellow lights. The color of lights affects the appearance of objects at night. Incandescent lamps offer the closest lighting to natural daylight, yet are the most

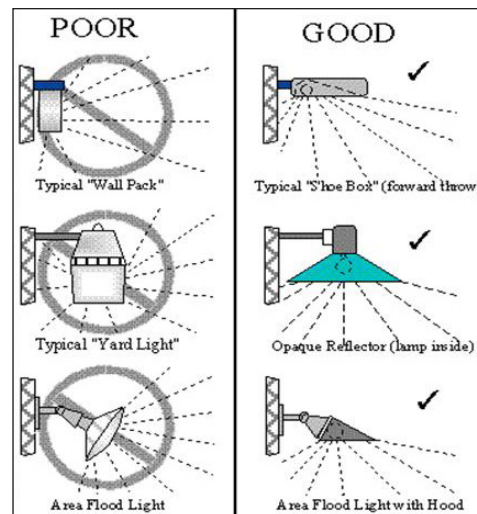
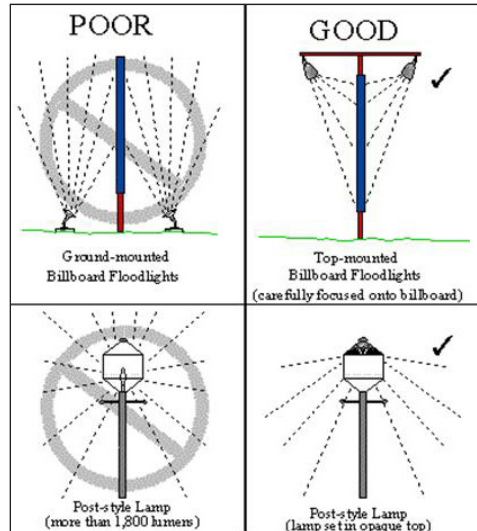

How Can We Promote Good Lighting? continued

5. **CONSIDER THE COLOR RENDERING INDEX.** This term is a scale used to describe the visual effect of light on colored surfaces. Natural daylight is assigned a color rendering index of 100. The scale is shown in the table below. There are times, such as in historic districts, where good color rendering is important. However, the lights that produce the best color rendering may also be the least energy efficient.

COLOR RENDERING INDEX VALUES FOR LIGHT SOURCES	
LIGHT SOURCE	CRI
Clear Mercury	17
White Deluxe Mercury	45
Warm White Fluorescent Tube	55
Cool White Fluorescent Tube	65
Deluxe Warm White Fluorescent	73
Daylight Fluorescent	79
Metal Halide 4200K	85
Deluxe Cool White Fluorescent	86
Metal Halide 5400K	93
Low Pressure Sodium	0-18
High Pressure Sodium	25
100-watt Incandescent	100

Source: Illuminating Engineering Society of North America

6. **SET UNIFORMITY RATIOS.** Since drastic changes in lighting intensity are difficult for the human eye to accept, many lighting manuals recommend a uniformity ratio. This term refers to the ratio of average illumination to minimum illumination. For example, if the maximum uniformity ratio for a parking lot is 4:1 and the average light level (4) is 3.0 foot candles, then the minimum light level (1) at any point within the parking lot must be at least 0.75 foot candles.

7. **SPECIFY LIGHT IN LUMENS.** Traditionally, the illumination power of a light source has been rated according to the energy needed to run the light (watts). Modern lights need less power to produce the same number of lumens. When an incandescent light is replaced by an High Pressure Sodium (HPS) lamp, less power is needed to produce the

same amount of light. If the amount of power used remains the same, then more light is produced. The table below provides typical examples of the number of lumens produced by a single watt of electricity.

LUMENS PER WATT	
Incandescent	7-24 lumens per watt
Halogen	12-36 lumens per watt
LED's 9/06	29-45 lumens per watt
Cree experimental unit	131 lumens per watt
Mercury Vapor	20-63 lumens per watt
Compact Fluorescent	44-80 lumens per watt
Fluorescent (tubular)	33-100 lumens per watt
Metal Halide	60-125 lumens per watt
High Pressure Sodium	60-140 lumens per watt
Low Pressure Sodium	90-180 lumens per watt

Source: Island Astronomy Institute

8. **REQUIRE TIME LIMITS ON CERTAIN LIGHTING.** Some towns require a lower level of lighting when a facility is not open to the general public. For example, parking lot lighting may be reduced after hours. Similarly, sign lighting may be shut off or reduced when the store that is being advertised is closed.

9. **SET HEIGHT AND SPACING STANDARDS.** To allow for downward-directed lights, fixtures need to be placed high enough (25-35 feet) so that they can appropriately illuminate their target. The fixtures should be positioned so that the lighted areas from each fixture do not overlap each other. It is important, however, to avoid excessively tall light poles since they may have a negative aesthetic impact. If a site is located on a top of a rise and will be viewed from below, tall poles may cause glare-related problems. Lower height poles (10-15 feet) create a more intimate and pedestrian friendly space that are better suited for downtown areas.

# What are Guidelines for Effective Outdoor Lighting?

Lighting guidelines should reflect the different needs of the various parts of a town. Some general guidelines follow.

RECOMMENDED FOOT CANDLE STANDARDS		
Land Use	Minimum Foot Candles	Maximum Foot Candles
Pedestrian areas / sidewalks	0.2	1.0
Building entries	1.0	5.0
Street lighting	0.2	1.0
Parking areas w/ high nighttime activity	2.0	4.0
Parking areas w/ low nighttime activity	0.2	2.0
Playgrounds	---	5.0
Sports grounds	---	20.0
Site perimeter	---	0.5
Local road (residential)	0.3	0.4
Collector road (commercial)	0.8	1.0
Source: North Carolina Dark Skies Association & Chittenden County Regional Planning Commission		

## Downtowns

These are areas more dependent on pedestrian traffic, and well designed façade lighting may be as important as having well illuminated sidewalks. Some towns require that façade lighting be turned off at the close of business hours. While the Illuminating Engineering Society of North America (IESNA) Lighting Manual recommends that street lights in downtown areas be spaced 300 feet apart and have a height of 30 feet, this may be excessive for smaller towns. For the smaller scale downtowns that typify most Maine communities, a lower height of 10-15 feet with closer spacing may be more appropriate.

## Historic Districts and Buildings

Fixtures that resemble lights appropriate to the period of the district are generally available from lighting manufacturers. These can be installed with shields and other devices that avoid light pollution. Generally speaking, the height

of lights should be lower than in commercial and industrial areas. Since each light would shine over a smaller area, more light fixtures might be needed. Some towns require incandescent lights in historic districts in order to assure the highest color rendering index.



## Industrial/Strip Commercial

While higher limits on foot candles and fixture height are normally advised, it is important to avoid over-lighting. Light trespass can be mitigated by requiring a reduction in lighting during the hours that the business is closed.

## Shoreland areas

It is important to assure that lights are shielded not only from surrounding properties but on the water side as well, since lights shining out onto the water can be seen for many miles. Lights on the exteriors of near-shore structures should have opaque shields to prevent direct visibility of the lamp to persons on public waters or adjoining lands. A Wisconsin ordinance recommends that lamps be not directly visible from more than 50 feet.

Public marinas may also need light regulation. The Wisconsin ordinance recommends use of opaque or shielded lights and that signs facing the water be limited to those necessary to comply with federal, state and local regulations and convey safety and related essential information. Illuminated signs should not be visible off the near-shore structures.

## Rural/conservation areas and parks

Lighting should be kept to a minimum in these areas. Shielding of allowed fixtures is very important.

Since regulating lighting on rural residential properties is a sensitive issue, land owner education may be a more effective strategy. Lighting impacts could also be addressed through the subdivision review process. Subdivision applicants could be required to show the lighting impacts of their developments.

## Uses with special lighting needs such as airports, harbors, security facilities, communication towers

Federal and state standards dictate many of the lighting requirements for these uses. Local ordinances need to

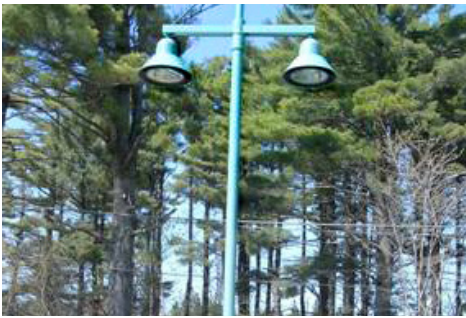

An example of well- shielded lighting.



Historic lighting fixtures should also be given appropriate shielding.

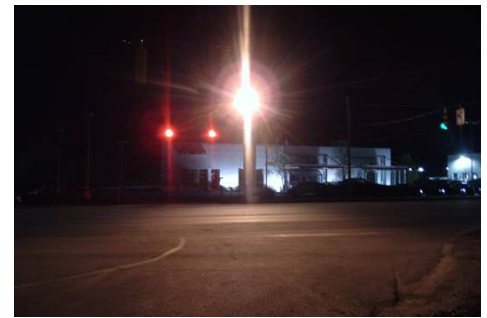

An example of excessive glare.

What are Guidelines for Effective Outdoor Lighting? continued

ensure that these uses comply with, but do not exceed other government standards. Here again, shielding to avoid lights shining off-premises should be encouraged.

Parking lots

The IESNA Lighting Handbook includes lighting guidelines for parking areas, both open and enclosed. The guidelines for open parking facilities suggest that a basic minimum level of illumination (at the darkest point of the lot) of 0.2

foot-candles is necessary in areas of low nighttime activity. As activity levels increase, the minimum level of needed illumination also increases to a point.

To avoid severe contrasts in lighting levels in different parts of the parking area, the IESNA guidelines suggest that the uniformity ratio not exceed 4:1. This, in conjunction with a minimum illumination level of 0.6 foot-candles, would yield an average level of illumination no higher than 2.4 foot-candles.

The IESNA guidelines are meant to serve as a basis for design. The guidelines, by themselves, do not address off-site community impacts of lighting, such as excessive lighting levels, glare, color and sky glow. It is these issues that communities may wish to address via local control and regulation.

Municipalities may prevent excessive lighting levels in parking areas by adopting standards similar to the IESNA guidelines, but that also provide some upper limit to lighting levels. This can be done by specifying an upper limit to the illumination level of the darkest point on the parking area, along with a maximum uniformity ratio that limits the average illumination level for the entire parking area. With these limits in place, there may be bright spots on the parking area, but they will be restrained by the need to keep the average below the specified level.

Gasoline station/canopies

Gasoline stations and convenience stores tend to be brightly lit since they seek to attract customers at night. The canopies over gas pumps may be very bright, sometimes measured at over 100 foot-candles. Shielding

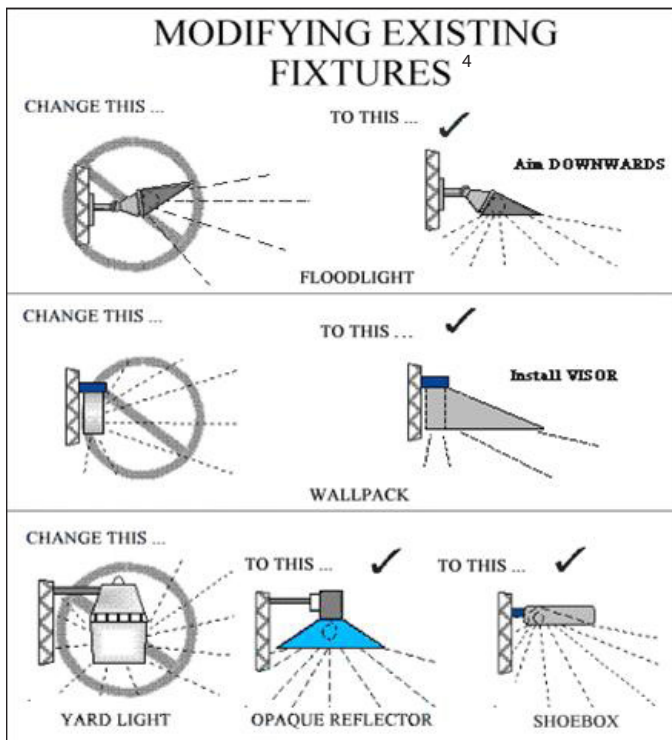

What are Guidelines for Effective Outdoor Lighting? continued

may be inadequate, contributing to glare. In most gasoline station/convenience store situations, the apron consists of two parts: the area immediately around the gasoline pumps (and under the canopy if there is one), and the more remote area around the periphery of the apron. The former area is where more visibility is needed to operate the pumps. These areas require a higher level of light than the outlying areas, which are used primarily for vehicle storage or parking. Lighting for these outlying areas should be comparable to that of parking lots.

Research compiled by the Chittenden County (Vermont) Regional Planning Commission on gasoline station lighting suggests that average illumination levels in excess of 10 foot-candles serve no purpose other than attracting attention to the site. The IESNA guidelines recommend an average illumination level of 20 foot-candles.

Glare from canopy lighting is caused primarily by ceiling-mounted light fixtures that send light beyond the canopy overhang. A solution, according to the Chittenden County Regional Planning Commission, is to require recessed fixtures so that the rim of the fixture and/or the edge of the canopy serve as a shield to confine direct light to a cone no more than 85 degrees from the vertical. Glare coming from light fixtures serving the remote areas of the apron can be controlled by requiring the use of cut-off fixtures designed to direct light onto the paved apron and not onto adjacent properties.

Exterior sales areas

There are certain commercial operations that use a very high level of lighting to attract customers. Examples include heavy equipment and automobile dealers, building materials and garden supply centers. Lighting levels for exterior sales and display areas need not match those of interior

spaces. If a store is closed, the observations occur mainly by walking or driving past the premises.

An average illumination level of 5.0 foot-candles is generally adequate for active sales/display areas. Lighting for parking areas of the operation should follow standards recommended for other parking areas. A uniformity ratio of no more than 4:1 should be established for the sales and display areas. Most lighting of outdoor display/sales areas uses either color-corrected HPS lamps or metal halide lamps. In order to ensure that these lamp types are used, regulations could specify a minimum CRI (Color Rendering Index) of 70.

Some towns require that outdoor display areas be shown in the initial site plan review application. It is important that town ordinances require review of parking areas that are subsequently converted to display space.

Exterior sports/performance facilities

These uses cover a variety of facilities from ice skating rinks and tennis courts, to larger spectator sports facilities and outdoor performance centers. The IESNA Lighting Manual has different standards for each use. Parking areas and pedestrian walkways should meet the general standards articulated elsewhere in this manual.

Planning board permit applicants should be required to submit a lighting plan prepared by a qualified lighting designer that documents the need for the proposed level of lighting. The plan should also document that all lighting fixtures are aimed at the playing areas and minimize light trespass, glare and sky glow. The planning board review criteria could also include energy efficiency standards.

Here are a few preliminary steps that a town should take



Typical gas station.

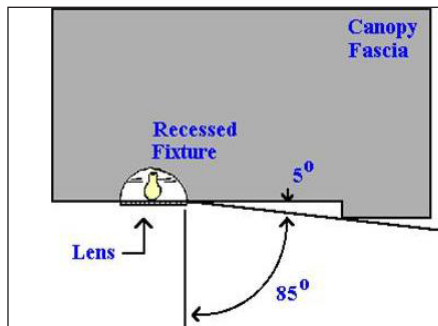

An example of shielded gasoline canopy lighting fixture.<sup>5</sup>

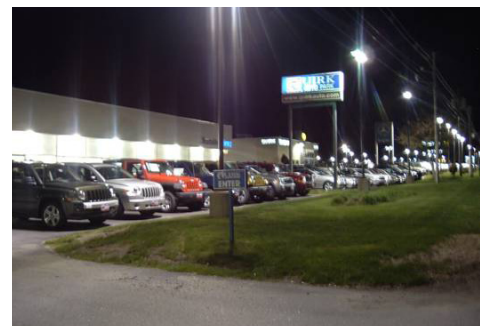

Common sales display area lighting.



# How Do We Implement Outdoor Lighting Standards?

before drafting lighting standards.

## Identify lighting issues in the comprehensive plan

As part of the data collection process for the comprehensive plan, it is important to identify lighting issues. First, during the public outreach process (such as surveys and visioning sessions) ask for citizen help in identifying lighting concerns. For example, when asked to identify community attributes citizens might identify dark skies. Second, identify areas where light pollution is a problem, such as a residential area that adjoins a commercial area. Third, think of lighting issues when designating growth and rural areas in the future land use plan. As with any other form of land use regulation, one needs to think of the different needs of various parts of town. For example, residential growth areas are more likely to attract development if they are relatively protected from light pollution. Fourth, be sure that recommendations on future commercial development address lighting concerns. This may involve recommending specific ordinance changes that address the various lighting issues raised in this bulletin. Fifth, be sure that the recommendations have reasonable exceptions for holiday lighting.

## Reach out to the business community and public safety officials

The business community may be concerned that lighting restrictions will affect its ability to attract customers and advertise its products. It is important to have outreach meetings with the business community through groups such as the chambers of commerce. Consider having a computer-generated slide presentation with examples of successful lighting from local businesses. (Hint: to avoid offending anyone it is best to have examples of poor lighting from other towns rather than local businesses).

It may also be helpful to meet with your local police chief to hear the police department's concerns about security lighting. Explain that the purpose of the proposed lighting standards is to decrease the risk of glare. It is important to listen to any security concerns the department may have.

## Contact state agencies that may be involved in lighting decisions

Under current Maine law (30-A MRSA Section 4352.6), state agencies are generally required to comply with local zoning unless there are unusual circumstances. It is important to assure that lighting associated with state facilities meets any local zoning requirements.

## SAMPLE LIGHTING ORDINANCE

No town should ever adopt standards directly from another town. Rather, it needs to review the standards carefully to see if they apply to their community. The example presented here is modified from Great Falls, Montana.

### I. AUTHORITY

This Ordinance is adopted pursuant to Home Rule Powers as provided for in Article VII Part 2, Section 1 of the Maine Constitution and Title 30-A, MRSA, Section 3001 et seq.

### II. SHORT TITLE

This Ordinance will be known and may be cited as the "Lighting Ordinance of the Town of \_\_\_\_\_ Maine", and will be referred to as this "Ordinance".

### III. STATEMENT OF NEED and PURPOSE

The town/city of \_\_\_\_ recognizes the following:

1. Improperly located lighting can cause unsafe and unpleasant condition;
2. Excessive lighting can cause unsafe, unhealthful and unpleasant conditions, waste electricity and threaten the natural environment;
3. Obtrusive lighting can cause unsafe and unpleasant conditions;
4. Proper lighting can enhance safety and enjoyment of the built environment;
5. On balance, lighting with a higher color rendering index (CRI) provides more desirable lighting than lighting with a lower CRI; and.
6. Illumination levels should be appropriate to the visual task.

This ordinance is established to promote the public health, safety, and welfare and is intended to accomplish the following purposes:

1. Allow appropriate lighting levels to preserve safety, security, and the nighttime use and enjoyment of property;
2. Reduce light pollution, light trespass, glare, and offensive lighting;
3. Promote energy conservation;
4. Allow people in residential areas to view the stars against a dark sky;
5. Enhance the aesthetics of the built environment; and

Sample lighting Ordinance continued

6. Protect the character of the natural environment and preserve ecological values.

IV. APPLICABILITY

A. **New construction/uses.** The provisions of this ordinance apply to parking lots, buildings, structures, and land uses established after the effective date of this ordinance.

B. **Expansion and redevelopment.** The provisions of this ordinance apply to the entire building/structure, parking area, or use, as appropriate, under the following conditions:

1. when a building or structure is expanded in size by 25 percent or more;
2. when the area of a parking area is expanded by 25 percent or more;
3. when an outdoor use (e.g., outdoor storage, vehicle sales) is expanded by 25 percent or more; and
4. any other activity subject to site plan or subdivision review.

*COMMENT: This provision needs to be modified to reflect the provisions your community has in its site plan and subdivision ordinances.*

The stated thresholds apply to a single addition or cumulative additions occurring after the effective date of this ordinance.

C. **Exemptions.** The following are exempt:

1. lighting required by the Federal Aviation Administration (FAA) for aviation control/safety;
2. seasonal lighting displays using low-wattage lamps between November 15 through January 15 of the following year;
3. lights used by police, fire, and medical personnel during an emergency;
4. luminaires attached to a residential building which are less than 2,000 lumens and mounted below the eaves; and
5. lighting placed underwater to illuminate swimming pools or fountains, for lamp type and shield standards only.

V. SEVERABILITY and CONFLICTS WITH OTHER ORDINANCES

A. **Validity and Severability:** Should any section or provision of this Ordinance be declared by the courts to be invalid,

such decision will not invalidate any other section or provision of this Ordinance.

B. **Conflict with Other Ordinances:** Should any section or provision of this Ordinance be found to be in conflict with any other municipal ordinance or regulation, the more stringent section or provision prevails.

VI. PROHIBITED LIGHTING

The following types of outdoor lighting are specifically prohibited:

1. lighting that could be confused for a traffic control device;
2. lighting that is oriented upward, except as otherwise provided for in this ordinance
3. searchlights, beacons, and laser source light fixtures;
4. lights that blink, flash, move, revolve, flicker, change intensity, or change color;
5. any lamp or bulb when not within a luminaire and which is visible from the property boundary line of the parcel on which it is located, except for landscape ornamental lighting; and
6. lighting inside of an awning when the awning material is translucent.

VII. GENERAL STANDARDS

A. **Illumination level at property boundary line.** When a commercial or industrial use abuts a residential use, lighting must be designed so that the illumination at the property boundary line that is attributable to the subject property does not exceed 0.3 foot-candles. When a commercial or industrial use abuts a public right-of-way, or another commercial or industrial use, lighting must be designed so that the illumination at the property boundary line does not exceed 1.0 foot-candles;

*COMMENT: Be sure to adjust this section to reflect the zoning districts in your community.*

B. **Pole-mounted luminaires.** Luminaires must not be taller than 15 feet in residential and downtown zoning districts or when placed within 50 feet of a residential zoning district. In all other zoning districts, luminaires must not be taller than 30 feet;

Sample Lighting Ordinance continued

**C. Building-mounted luminaires.** In non-residential zoning districts, building-mounted luminaires must not be attached to a sloped roof and must not be taller than 30 feet or the height of the principal building, whichever is less. The use of wall-mounted unshielded luminaires (e.g. “wall-pack”) is discouraged;

**D. Overhead electrical lines prohibited.** For new installations, electrical lines for luminaires mounted on freestanding poles must be placed underground between poles. This requirement does not apply to rural residential areas except as otherwise noted in the town of \_\_\_\_\_ subdivision ordinance;

**E. Material for light poles.** Light poles must be anodized, painted or otherwise coated so as to minimize glare from the light source;

**F. Continued maintenance.** Lighting installations must be maintained in good repair to meet the provisions of this ordinance on an on-going basis;

**G. Lighting curfew.** For parcels with non-residential uses, lighting in vehicle parking areas containing 20 parking spaces or more must be reduced to 50 percent of permitted levels one hour after the business closing to one hour before the business opens. If lighting levels are already below 50 percent of permitted levels, no curfew adjustment is required;

**H. Luminaire types.** Full-cutoff luminaires must be used in parking areas, along internal streets, and along pedestrian ways. The City/town may allow cutoff luminaires or semi-cutoff luminaires in these locations when the overall uplight would be less than for full-cutoff luminaries. To promote a unified development theme, post top luminaires (also referred to as period lighting) may be used as an alternate if they have built-in reflectors that effectively eliminate uplight. Except as provided in this ordinance, all other luminaires must be directed downward and the light source must be shielded so that it is not visible from any adjacent property;

**I. Maximum average lighting levels.** Average lighting levels must not exceed the standards provided for in Exhibit 1. For those areas not specified, the planning board must work with the applicant to set an appropriate level on a case-by-case basis in keeping with the intent of this ordinance;

**J. Maximum uniformity ratio.** In all parking areas and along

sidewalks and other pedestrian walkways, an average to minimum uniformity ratio of 6:1 or better must be maintained;

Exhibit 1. Maximum average light levels	
Location	Foot candles
At entries for residential, commercial, and industrial buildings	5.0
At loading areas (berths) associated with a commercial or industrial use	10.0
In parking areas for multi-family uses	3.0
In parking areas for non-residential uses	5.0
Along sidewalks and other pedestrian walkways	3.0
Under service station canopies	10.0
In general storage areas for commercial and industrial uses	8.0
In vehicular display areas	10.0

**K. Minimum color rendering index (CRI).** In all parking areas and along sidewalks and other pedestrian walkways, lighting must meet or exceed the minimum color rendering index as provided for in Exhibit 2.

Exhibit 2: Minimum color rendering index (CRI) for parking areas and pedestrian ways	
District	Minimum CRI
Residential zoning districts	60
Downtown	60
Mixed-use zoning districts	60
Commercial zoning districts except downtown	20
Industrial zoning districts	20
Historic District	80

VIII. SPECIAL STANDARDS FOR SPECIFIC APPLICATIONS

These standards are in addition to the foot candle standards and CRI standards specified in Exhibits 1 and 2.

**A. Flag poles, statues and similar monuments.** A flag pole bearing a state flag, a flag of the United States or a flag of a foreign nation may be illuminated, provided the following standards are met:

Sample Lighting Ordinance continued

1. The luminaires must be fully shielded.
2. Upward aiming luminaires must be placed as close to the base as possible.
3. The luminaires must not collectively exceed 40,000 mean lumens.

Public statues, memorials or other similar monuments may also be lighted upon approval by the planning board, provided the above standards are met.

**B. Building façade lighting.** The exterior of a building may be lighted provided the following standards are met:

1. The lighting is done to accentuate an architectural or aesthetic element of the building, not the entire building.
2. The light must only be directed onto the building façade and not spillover beyond the plane of the building.
3. Upward aimed lighting must not exceed 4,000 mean lumens per accent feature, must be fully shielded, and mounted as flush to the wall as possible.
4. Lighting exceeding 4,000 mean lumens per accent feature must be aimed downward, fully shielded, and mounted as flush to the wall as possible.

*COMMENT: if your community has a sign ordinance, be sure to check for any potential conflict between standards.*

**C. Sign lighting.** Signs may be lighted consistent with the following standards:

1. Ground signs that are less than 6 feet in height may be internally lit, lighted from above provided the luminaire is no taller than the top of the sign, or lighted with ground-mounted lights provided the lights are fully shielded and mounted as close to the sign base as possible.
2. Ground signs 6 feet in height or taller may be internally lit or lighted from above provided the luminaire is no taller than the top of the sign.
3. Wall signs may be internally lit or lighted with ground-mounted lights provided the lights are fully shielded and mounted as close to the wall as possible.

**D. Canopy lighting.** Lighting associated with a canopy used for a vehicular shelter must meet the following standards:

1. Luminaires beneath a canopy must be either a full-cutoff luminaire or mounted so the luminaire or lens, which ever is lower, does not project below the bottom of the canopy surface.

2. The sides or top of the canopy must not be illuminated, except as permitted by the sign lighting standards.

3. Lighting installed beneath a canopy must be pointed downward and substantially confined to the ground surface directly beneath the perimeter of the canopy.

4. Lighting beyond the perimeter of the canopy must be consistent with the lighting standards for parking areas.

**E. Telecommunication facilities.** Telecommunication facilities must be unlit, except for the following:

1. A manually-operated or motion-detector controlled light above the equipment shed door which must be kept off except when personnel are actually present at night.

2. The minimum tower lighting required by the Federal Aviation Administration or other state or federal requirement. Where tower lighting is required, it must be shielded or directed to the greatest extent possible in such a manner as to minimize the amount of light that falls onto nearby properties, particularly residences.

**F. Recreational facilities.** Lighting for outdoor athletic fields, courts, or tracks must meet the following standards:

1. Lighting installations must be designed to achieve no greater than the minimal illuminance levels for the activity as recommended by the Illuminating Engineering Society of North America (IESNA).

2. Light trespass and glare must be reduced to the greatest extent possible given the illumination constraints of the design. When an outdoor athletic field abuts a residential district, lighting as a goal should be designed so that the illumination at the property boundary line that is attributable to the subject property does not exceed 0.5 foot-candles.

3. Lighting used to illuminate the athletic surface must be turned off within one hour after the last event of the night.

4. Lighting must be designed by a registered engineer having experience with lighting installations.

**IX. DEFINITIONS**

**A. Construction of language.**

1. In this Ordinance, certain terms or words should be interpreted as follows:

- a. The word “person” includes a firm, association, organization, partnership, trust, company, or corporation, as well as an individual;

## Sample Lighting Ordinance continued

b. The present tense includes the future tense, the singular number includes the plural and plural includes the singular;

c. The words “will, must, or shall” are mandatory;

d. The word “may” is permissive;

e. The words “used” or “occupied” includes the words “intended”, “designed”, or “arranged to be used or occupied”; and

2. Terms not defined shall have the customary dictionary meaning.

### B. Definitions of words.

For the purpose of interpreting this Ordinance, the following terms, phrases, words and their derivations shall have the meaning given herein.

“Color rendering index (CRI)” means a measurement comparing the color of an object under a light source to a reference light source of comparable color temperature. CRI values generally range from 0 to 100. As the CRI approaches 100, the color of the lit object becomes truer or closer to the original color.

“Cutoff luminaire” means a luminaire where less than 2.5 percent of the lamp lumens occur at or above the horizontal plane and no more than 10 percent of the lamp lumens occur above 80 degrees.

“Foot-candle” means a measure of light falling on a given surface. One foot candle is equal to one lumen per square foot.

“Full-cutoff luminaire” means a luminaire where no light occurs above the horizontal plane and no more than 10 percent of the lamp lumens occur above 80 degrees.

“Glare” means luminance in excess of what the human eye is accustomed to resulting in annoyance, discomfort, or loss of visual performance and visibility.

“Illuminance/Illumination” means the amount of light falling on a surface. Illuminance may be measured in lux or in foot-candles.

“Illuminating Engineering Society of North America (IESNA)” means a professional organization that was created to advance knowledge and disseminate information for the improvement of the lighted environment to the benefit of society. Its membership includes engineers, architects, de-

signers, manufacturers, contractors, distributors, utility personnel, educators, students, and scientists.

“Light level/Lighting level” see “Illuminance/Illumination”

“Light meter” means a device that measures the amount of light energy falling on a given surface.

“Light trespass” means light emitted by a lighting installation that falls outside the boundaries of the property on which the installation is sited.

“Lighting fixture” See: luminaire.

“Lumen” means a measure of light energy generated by a light source. Manufacturers list ratings for all their lamps. Average lumen ratings are slightly lower than initial lumen ratings.

“Luminaire” means a complete lighting unit consisting of a light source and all necessary mechanical, electrical, and decorative parts.

“Nadir” means the angle pointing directly downward from the luminaire, or 0°.

“Non-cutoff luminaire” means a luminaire where a considerable amount of light occurs above the horizontal plane.

“Security lighting” means outdoor lighting used for, but not limited to, illumination for walkways, roadways, equipment.

“Semi-cutoff luminaire” means a luminaire where less than 5 percent of the lamp lumens occur above the horizontal.

“Uniformity ratio” means the ratio of average illumination to minimum illumination within a given area.

“Uplight” means light emitted upward by a luminaire.

## Selected Bibliography

American Planning Association, Zoning Practice/Ask the Author, August 2004. [www.planning.org/zoningpractice/askauthor/04/askauthor0804.htm](http://www.planning.org/zoningpractice/askauthor/04/askauthor0804.htm)

Boone, North Carolina, Community Appearance Commission, Commercial Development Appearance Standards

<http://www.physics.appstate.edu/caton/NCDarkSkies/Ordinances/BooneLighting062705Illustrated.htm>

City of Burlington, Vermont Design Review Guide: Outdoor Lighting, <http://www.ci.burlington.vt.us/planning/dguide/lighting.pdf>

City of Great Falls, Montana, Official Code, Chapter 40, Outdoor Lighting. [http://www.ci.great-falls.mt.us/city\\_codes/landsign/40-5-outdoorlightingnew.pdf](http://www.ci.great-falls.mt.us/city_codes/landsign/40-5-outdoorlightingnew.pdf)

Good Neighbor Outdoor Lighting, New England Light Pollution Advisory Group and the International Dark Sky Association, May 1995, <http://www.darksky.org/handouts/gnol.html>

Guidance notes for the Reduction of Light Pollution, Institution of Lighting Engineers, <http://www.ile.org.uk/index.php?page=pollution>

Illuminating Engineering Society of North America (IESNA), various information sheets, <http://www.iesna.org/>

International Dark Sky Association, various information sheets, [www.darksky.org/resources](http://www.darksky.org/resources) ;

Island Astronomy Institute, <http://www.islandastro.org/>

Light Pollution: Questions and Answers Hampshire County Council (U.K.), [www.delscope.demon.co.uk/information/lightpollution.htm](http://www.delscope.demon.co.uk/information/lightpollution.htm)

Lighting Research Center at Rensselaer Polytechnic Institute,

general information [www.lrc.rpi.edu](http://www.lrc.rpi.edu)

Outdoor Lighting Manual for Vermont Municipalities, Chittenden County Regional Planning Commission, 1996

Outdoor Lighting, New Hampshire Office of Energy and Planning, Spring 2007

[www.state.nh.us/oep](http://www.state.nh.us/oep)

Town of Kennebunkport, Maine, Kennebunkport Outdoor Lighting Ordinance <http://www.town.kennebunkport.me.us/Home/>

## Endnotes

1 <http://www.dominionelectric.com/faq-idsa.htm>

2 <http://www.dominionelectric.com/faq-idsa.htm>

3 <http://www.darksky.org/handouts/gnol.html>

4 <http://www.darksky.org/handouts/gnol.html>

5 Boone, North Carolina Lighting Ordinance



Financial assistance was provided by the Maine State Planning Office through the Office of Ocean and Coastal Resource Management, National Oceanic and Atmospheric Administration, US Department of Commerce, under the Coastal Zone Management Act of 1972. This report was prepared by the Hancock County Planning Commission and the Maine State Planning Office under award #NA04NOS4190041 from the National Oceanic and Atmospheric Administration, U.S. Department of Commerce. The statements, findings, conclusions, and recommendations are those of the author(s) and do not necessarily reflect the views of the National Oceanic and Atmospheric Administration or the Department of Commerce.